

## Section 2 : Fast Gearbox RT11509C Structure & Working Principle

No overall by as shown in Figure 1-4, RT11509C gear box of a with five forward gears and a reverse gear box and a high and low gear side gearbox combination into a has 9 forward gears (1 to 8 files and a creeper gear) and a reverse gear type gearbox (5 in gear and a reverse gear main gear box and a high and a low speed side gearbox combination 10 forward gears and a reverse gear. However, due to the high speed creeper gear and high-speed reverse significance. From the control mechanism of the two stalls removed, thereby forming nine forward gears and a reverse gear. The main tank and auxiliary box are taken In the back cover of the distance between two double shaft structure, they share a gearbox shell, shell has a baffle plate in the middle of the box and the box is divided into the main tank and auxiliary box. The main box counter shaft bearing in the gearbox casing and the clapboard and the second box and the front end of the shaft is inserted in the shaft hole, and the rear end is supported on the board. The gearbox output end a whole type end cover and transmission housing is connected in transmission housing with two positioning pin, to ensure that the rear end cover and the shell of the coaxial degree. Vice box with two auxiliary shaft is supported in the middle of the baffle plate and the rear end cover, side box output shaft with two disc cone bearing cantilever bearing end cover.

The conventional structure of gearbox is provided with only one axis, as shown in figure 2-1..

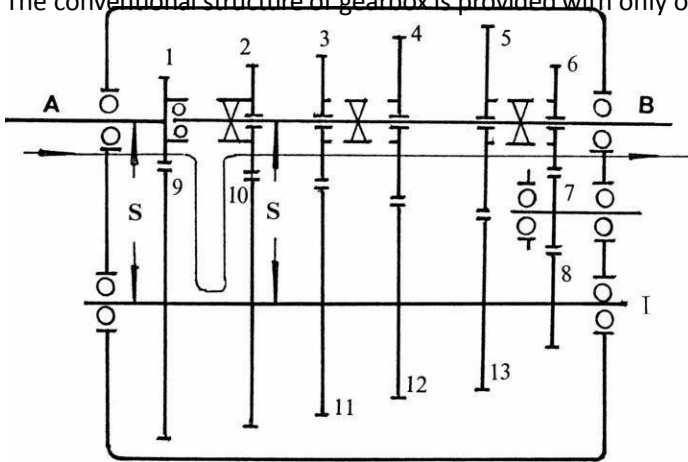

Figure 2-1 conventional transmission diagram

Figure 2-1 is a regular structure for 5th gear (five forward gears and one reverse) gearbox transmission diagram. This gearbox is usually by a shaft (input shaft), the intermediate shaft and the second shaft (output shaft). Power from an input shaft counter shaft passed to a second output shaft. Due to only one root axis, so the three shafts in the transmission of torque and also bear due to the radial force in gear meshing.

2-1, assuming the transmission box hanging gear, second shaft gear sets and third gear 2 occlusion, and then the power will by the a axis "a" through the driving gear 1 and an auxiliary shaft driven gear 9 will transfer power to the counter shaft, again through the counter shaft gear box 10 and second shaft gear box

2 to transmit power to the second output shaft. Meshing transmission torque at the same time, a shaft and the auxiliary shaft will also have a radial force "s", also in the counter shaft gear box 10 and two axis third gear meshing transmission torque at the same time shaft and two axis is also a radial force "s". Obviously the radial force and on the bearing of the shaft. Therefore in the design, not only to considering the size of the transfer torque, but also to take into account the effect of radial force on the shaft. Therefore, the conventional structure of the general of the

Counter shaft transmission gearbox of the three shafts must be done very coarse to the shaft in the radial force for deformation, gear box for each axis of the supporting bearings must choose the load bearing capacity of large. Not only that, the conventional structure of the gearbox gear in meshing transmission force, only in the meshing tooth force, while the rest did not enter into the gear teeth are all in "leisure". In other words, the Ministry of power is through a pair of meshing teeth, the gear must be manufactured. Fast gear box structure of the biggest characteristic is the use of double shaft structure, that is, in the conventional gearbox completely symmetrical another side to add a root vice Axis. Figure 2-2 is a double counter shaft gearbox 5 forward gears and one reverse gear transmission.

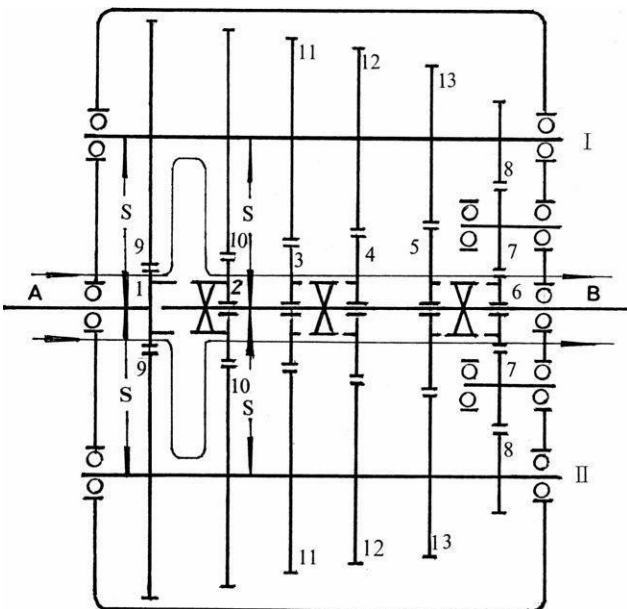

Figure 2-2 double counter shaft transmission diagram

From figure 2-2 shows that the transmission gear hanging hypothesis, powered by a shaft of the "A" input, through the driving gear 1 and two side

To design the auxiliary shaft of the driven gear 9, "one divides into two" were delivered to two "I" and "II". And then through two vice shaft gear box 10 and the second shaft gear box and gear sets, the power of "two combine into one" to transfer to the second axis "B" output. Obviously, in the main, driven gear 1 and 9 engaged two counter shaft gear to a shaft radial force "s", just equal and opposite offset each other, at the same time axis only undertake to transmit torque and no radial force, so a shaft can only according to the transfer of the maximum input torque shaft diameter size, and without considering the radial force generated in the bending deformation effect There are two this axis can be designed smaller, also support bearings can also choose a smaller models. Also, two counter shaft gear box through the second shaft gear gear of second shaft of two radial force "s" is equal to the size of the opposite direction offset each other, so the two axis does not bear the radial force, the design of shaft diameter according to deliver maximum output torque, and no need to consider the radial force bending deformation. So the second shaft is fine, the bearing can also choose the smaller models (two counter shafts still exist in size to force, so the axis of the shaft diameter still retains coarse design to ensure

greater To share the bending stiffness and counter shaft bearing is larger. At the same time, because of the two auxiliary shaft, two sets of counter shaft gears, therefore in the meshing transmission power when each pair of meshing teeth only take half power. Also is to say: a shaft and the second shaft gear, power is bilaterally symmetrical meshing teeth, each side of the meshing teeth only take half the power, so the Fast gear box gear thickness than to pass the same size power conventional gearbox reduce many theoretical thinning half, actually about thinning third). Because of the fast gear box shape is short and thick. Due to the double counter shaft, The main burden pick gearbox transmission is very stable, the noise is low. A example: the general structure of a conventional gearbox like us with a pole to two buckets of water in a head, is very laborious, and fast gear box is equivalent to a pole to two buckets of water were placed at both ends, obviously is very easy and smooth. The stable transmission, no need to adopt the helical gear and spur gear has been completely meet the requirements. The transmission is steady, the shift mechanism without using a synchronous device, in addition to the start gear "clutch brake work and vice box high, low-grade shift mechanism the syn chronizer, Fast gear box box adopts The production cost is greatly reduced by the use of the most simple meshing sleeve type gear shifting mechanism without the use of a synchronization device.

Transmission diagram is given in Figure 2-3 RT11509C gearbox, it can be seen that the main box fast gear box and the auxiliary box are

Double shaft structure. The main gearbox is a twin counter shaft transmission box with five forward gears (1 to 4 files and creeper gear) and a reverse gear. The gear shift mechanism is the traditional gear sets and no synchronizer. Auxiliary gearbox is also a pair of counter shaft structure, high, low-grade shift machine structure is high, low shift cylinder control of inertia lock Shaw type synchronizer to achieve.

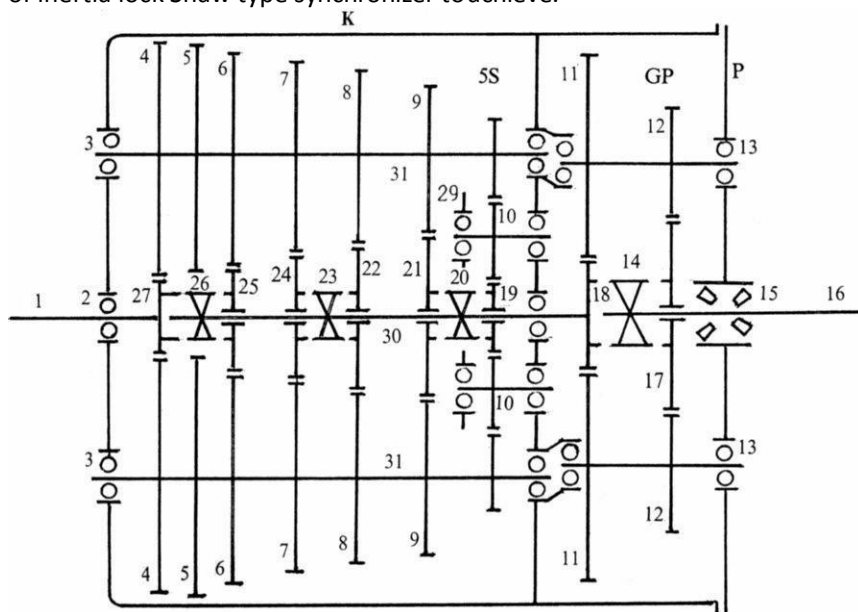

1. The main box a shaft 2, a shaft bearing. The main box counter shaft bearing counter shaft driven gear. The main box counter shaft take gear. The main box counter shaft gear box. The main box counter shaft second gear. The main box counter shaft first gear. The main box counter shaft creeper gear gear. The main box reverse idler gear shaft and

11. Vice box counter shaft passive gear 12. Vice box counter shaft output transmission gear 13. Vice box counter shaft bearing 14. Vice box high, low-grade synchronizer type hanging device file 15. Vice box output shaft double cone bearing

18. Box input driving shaft gear 19. Box main shaft reverse gear 20. Reverse a creeper gear meshing 23.1-2 set 21. The main box two axis creeper gear gear 22. Main box two axis first gear (5-6) gear is engaged in Set 24. The main box second shaft gear tooth round 25. The main box two axis third gear 26.3-4 (7-8) engaged gear set 27. The main box The main shaft of the driving gear box 28 reverse thrust bearing

29 main shaft box two 30 main box counter shaft (two symmetrical) K. gearbox shell P. auxiliary box rear cover

Figure 2-3 fast RT111509 type gear transmission diagram

Passive output controls the gear shift lever in the low (1 to 4) zone, double h shift valve (high and low shift valve) through the cylinder to push the synchronizer gear sleeve back and side box gear hang together, this time by the main box input power is composed of a driving gear 18 (Figure 2-3) and a counter shaft transmission gear 11 will power transmission to two auxiliary shaft. The gear 12 will power transmission to the vice box output gear 17 by the same step for meshing 14 sets of the power transmission to the vice box shaft 16 output. When the shift lever set high gear (5-8) region, double h shift valve through a shifting cylinder synchronization push forward and side box input shaft meshing. At this time by the power of the main gearbox input power transmitted directly to the vice box two axis 16 output, the realization of the direct file that the so-called double H shift valve that is high, low gear shift valve.

From Fig. 2-3 can see: the second shaft 30 of the front end of the main box is in the a axis active gear axle hole (note that this has no bearing, which is different from conventional gearbox), and on the other end is supported by the bearings in the shell of the gearbox. And vice box second shaft 16 is completely through the double cone bearing 15 cantilever support on the back cover of the side box.

Figure 2-4 provides fast RT11509C type gear power transmission diagram. From the figure we can vividly see the power in the main box

Divided into two and then transferred to the auxiliary box be made one, is also to be made one One divides into two..

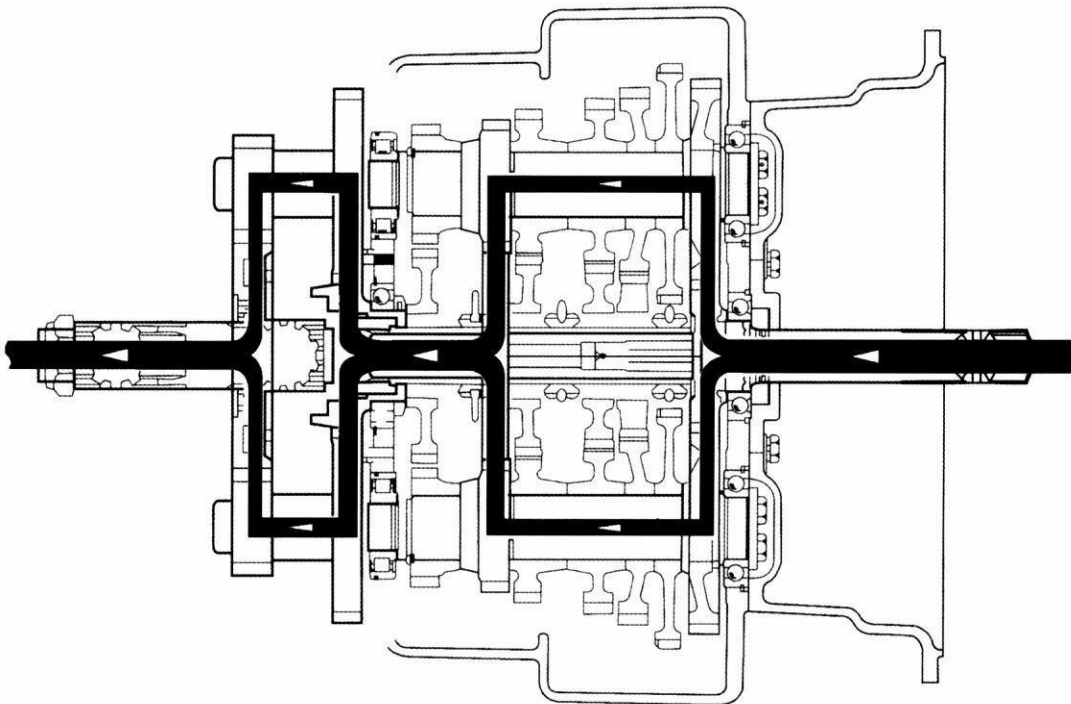

Figure RT111509C 2-4 gearbox power transmission diagram

Fast gear box due to the adoption of a twin counter shaft transmission, but also bring many structural characteristics of use and maintenance should note.

Size at the same time, the advantages brought by the first, in order to guarantee the full play twin counter shaft transmission, the second axis of each gear is not only an empty set of the second shaft and gear shaft hole and shaft radial also must have a mm radial clearance. In other words: second shaft gear is very Songkuang is sheathed on the second shaft. The structure and the conventional structure of the gearbox is completely different. It is to ensure that the twin counter shaft transmission power required. This is because of the gear in machining process can not guarantee that all gear

machining error completely consistent. As shown in Figure 2-3. Although the theory about force at any time by a shaft into two to two counter shaft by Root root root root I combined two counter shaft transmission to the second output shaft. But due to gear machining error, so that through the transmission counter shaft gear teeth side clearance cumulative deviation and through the second counter shaft gear teeth side clearance cumulative deviation, if the second gear shaft and the second shaft no radial Kuang and is concentric, will result in a moment the I shaft gear and the second gear meshing transmission, while the second counter shaft gear and the second gear shaft may have the tooth side clearance and engaged. In another moment of the second root side gear shaft and the second shaft gear occlusal transmission force and the I shaft gear and the second shaft gear meshing. Kuang or root root root I force for a while by the counter shaft transmission, while the second counter shaft transmission, in fact each counter shaft transmission all power, did not play a double shaft. In order to ensure that the second shaft gear anytime, anywhere and two counter shaft gear meshing transmission power, in other words: to make the power at any time should be divided into two two counter shaft and pass to the second shaft, it is necessary to make second gear shaft with respect to the second shaft is provided with a radial amount, the second shaft gear can freely on any clip in two counter shaft gear in the middle of the two counter shaft gear and the second gear shaft at any time in an engaged position. The second shaft gear sets and the second axis is by spending Key connection, in gear meshing sleeve and gear meshing force transmission process, the gear relative to the gear sets in terms of is in a state of relative to planar motion, thus requiring lubrication conditions to ensure strict.

In order to ensure the two axis gears are all at any time with the two counter shaft gear mesh at the same time, not only all two axis and two axis of a gear

The radial clearance, and second shaft and a shaft hole also uses floating structure. As shown in Figure 2-5, the second shaft into a shaft hole, not only the abolition of the bearing, and there are enough radial clearance with a two axis floating. This is with conventional gearbox main structure of different.

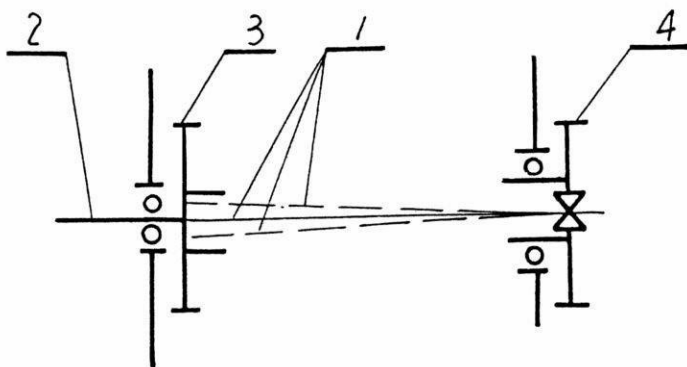

1 main shaft 2 input shaft 3 input shaft gear 4 gear box drive gear figure 2-5 gear box two shaft floating structure

Similarly, auxiliary transmission output shaft driving gear and an output shaft also abolished the needle roller bearing and shaft hole and shaft neck have a sufficient diameter to the gap. Vice box output shaft simply to take double cone bearing cantilever structure.

The twin counter shaft transmission mode, in maintenance and also with a conventional gearbox has bigger difference. Especially after the disintegration of the installation, only in a fixed position to make stall gear and two counter shaft stall gear of the second shaft all at the same time in an engaged state, in any other position are unable to mesh in place. Therefore, reassembled in the main transmission box or vice box after the disintegration of the need "to the tooth installing".

As shown in Figure 2-6, main gear box before installation, passive two counter shaft gear 1 and 2 in the pass keys correspond to the tooth face make a mark it for installation, and then with a

Drive shaft gear 3 symmetric gear (the two auxiliary shafts through keys in an axis) in the driving gear and the two counter shaft play marked adjacent two tooth face, also

Also playing on tooth marks, in the installation of a shaft, shaft and the second shaft must will of tooth alignment marks, all of the gear in order to be fully engaged in place, otherwise can not place. Vice box in two counter shaft transmission gear and the output gear shaft itself is engraved with of tooth marks, installation only will be engraved with markers of the tooth to the engaged teeth can be installed in place (see gearbox disassembly Festival). If the side gear box is not on the tooth marks, in much the same way as in the output shaft gear and two counter shaft gear do the tooth marks, and then assembled.

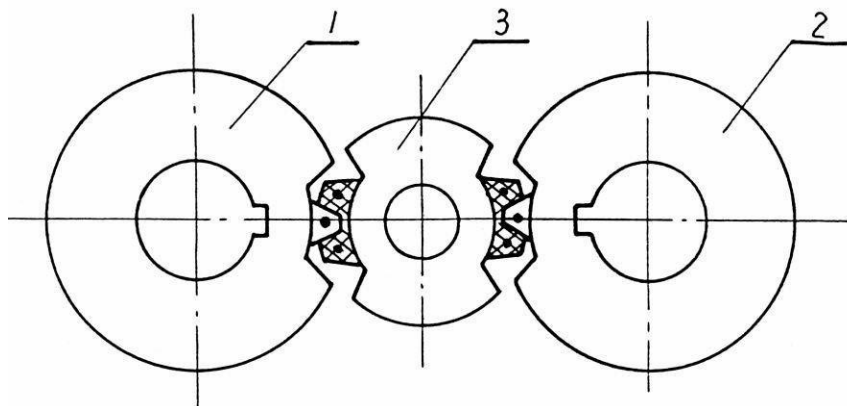

1 1 2 2 root counter shaft gear driven gear shaft 3 root counter shaft driving transmission gear Figure 2-6 schematic diagram of the installation of teeth

In actual maintenance tend to occur in such a situation: when installing paid no attention to tooth marks, and the results will be the axis gear assembly in place, just gearbox like "random file" can not be rotated. This is due to the long-term use of gear wear, open Zhou Chengsong, gearbox although not installed according to the "on the tooth installing" program, the tooth marks on wrong tooth occasionally can install, only transmission is the gear occlusal wringing strength could not be rotated.

Due to the characteristics of twin counter shaft transmission smooth, and file a, ratios of smaller, so main box no need to adopt the synchronizer gear shift mechanism, old-fashioned meshing sleeve shifting mechanism fully meet the requirements. As shown in Figure 2-7, engaging sleeve and the gear engagement end tooth at the same size 35 DEG cone angle alpha, the cone can play a certain automatic centering and synchronization.

The above mentioned is the car in the normal running, the shift is very convenient, but the car is not the beginning of this.

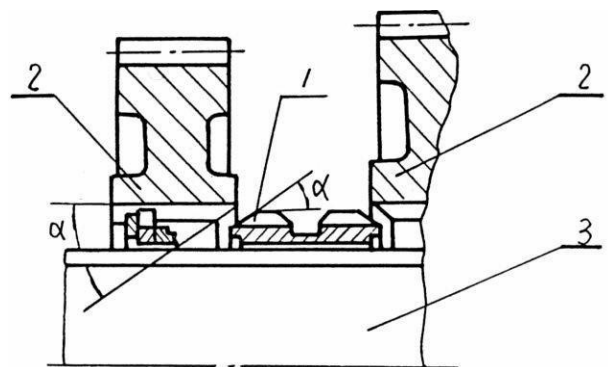

1 shift gear meshing gear two 3 shaft gear two 2 shaft figure 2-7 main box gear shift engagement sleeve

Still all obviously is in the car before starting the engine, clutch, transmission shaft continuously rotates. Due to a rotating shaft drives the counter shaft rotation shaft of each gear drives the second shaft gear in turn. At a time when the car suspended in this position, the second output shaft is stationary. From step gear and clutch while the gearbox and engine power was torn off. However, due to the motion of inertia, the gear in the rotation, a rotating parts and a completely stationary parts of the hanging is obviously more difficult. Therefore, Fast gear box of the starting gear is difficult. This is to

use a said: "the clutch implement

Brake mechanism to realize the hanging file synchronization. Clutch brake is composed by the clutch brake valve and clutch brake cylinder. There is a two bit three ventilation valve installed in the clutch pedal down, this is the clutch brake valve. When starting gear, foot

2 3 2 3 3 open top has a clutch pedal block position, indicating that the pedal arm to the top of the brake valve, the operation requirements and down pedal when the pedal arm will switch from the air storage cylinder of compressed air through the opening of relief valve opens to figure 2-8 shows mounted in the main box gear side window of the brake cylinder. Compressed air into the brake cylinder drive for cylinder piston and piston are arranged at the front end of a force taking gear outer circle arc concave, the piston in the pressure pressed in gear cylindrical surface, so that the power of the combined gear with the vice shaft overcome inertia brake quickly, the second shaft All gear stop rotation, starting gear is very lightweight hang together. When release the clutch pedal, braking switch valve under the action of a spring return completely, brake cylinder of the gas valve to drain, brake release, gearbox returned to normal

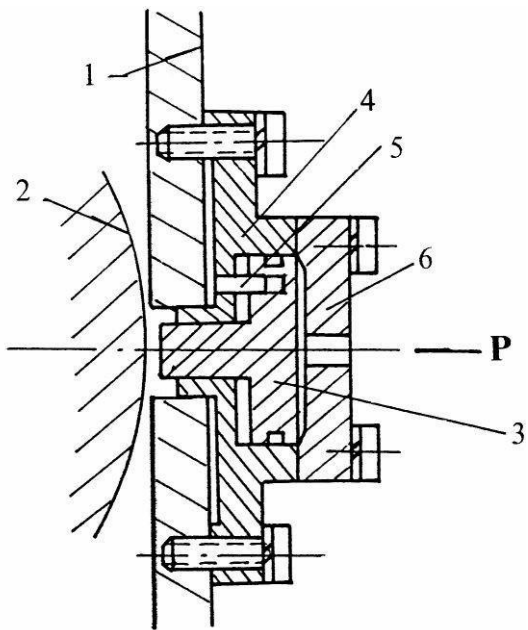

2. 1. Gear box shell counter shaft gear 3. Clutch brake cylinder piston. The clutch brake cylinder 5. Guide pin 6. Side cover figure 2-8 clutch brake cylinder

Operation. In fact, the clutch and brake is the role of a start synchronizer, just in a different working principle of synchronization and a synchronizer. Is worth pointing out: brake and clutch are only in the initial hanging file operation plays a role in the, vehicle in normal driving without such manipulation of the clutch and brake. Is limited by the figure 2-8 visible, the piston 3 travel, when the piston 3 face serious wear when, apparently clutch brake work will is poor or completely failure, showing the start of a hanging file.

The auxiliary gear box is high, and the low gear shift mechanism is the air control shift, so the inertia lock type synchronization device is adopted.

Figure 2-9.

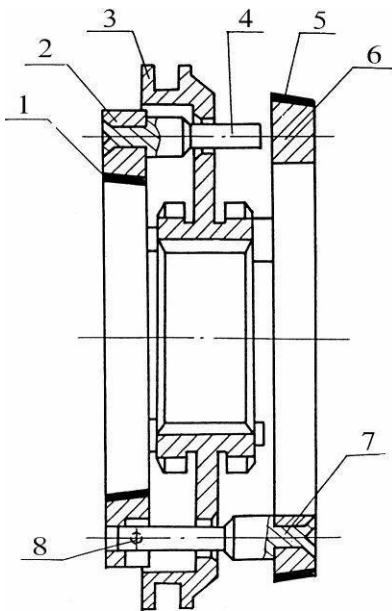

1. High speed synchronous cone ring Galen material 2. High speed synchronous cone ring 3. Meshing slip cover. The locking pin 5. Low speed file synchronization cone ring of Galen material material. Low speed synchronous gear cone ring latch.

Figure 2-9 vice box high, low-grade synchronizer high and low synchronous cone are and vice box input shaft gear and the output gear shaft of various. Main box adopts double h shift control mechanism, high combining side box, low-grade gas control shift mechanism the gearbox formed

The scope of a gear box 9 forward gears and one reverse gear.

The so-called double H shift mechanism, as shown in Figure 2-10, is in the main box shift of the control mechanism on the 1-2 file (low speed) and 5-6 (high speed)

The shift dial is one of the 3-4 files (low speed) and 7-8 (high speed) shift of the block is one of the blocks, but 1-2,3-4 and 5-6,

The 7-8 file is "H" - shaped in a staggered arrangement shown in Figure 2-10.

As figure 2-11 in the gearbox cover above installed one or two three-way valve (commonly known as the double h shift valve 15), when the shifting shaft lever in the 1-2,3-4 low-grade zone, shifting bar shows the position in the diagram, double h shift valve in low gear

A.1-2 (5-6) shift shifting block B.3-4 (7-8) shift block Figure 2-10 dual H shift mechanism

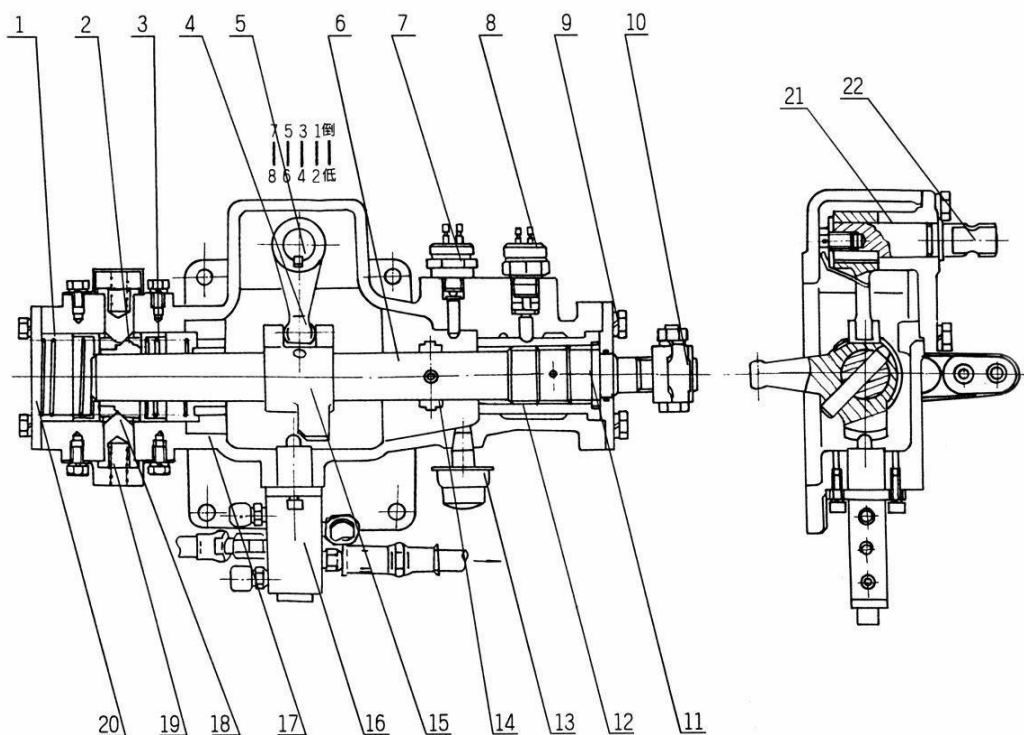



Dust proof set oil seal 3. Double H control device casing. Reverse switch control block. The shift lever. The shifting shaft. The balance spring. Locating ring. Locating plunger 11. Side plate 12. A compression spring 13.14.16. trachea 15. Double h shift valve 17. Ventilation plug 18. Shifting crankarm

Figure 2-11 single pole double H shift mechanism

Device, double h shift valve to the side gear shifting cylinder low-speed file work cylinder joint supply, and high speed cylinder joint 2 exhaust (see Figure 2-12), low profile cylinder of compressed air to push the piston 3 is pulled back, side gearbox shift 5-axis control synchronizer sliding sleeve to move after hanging low gear.

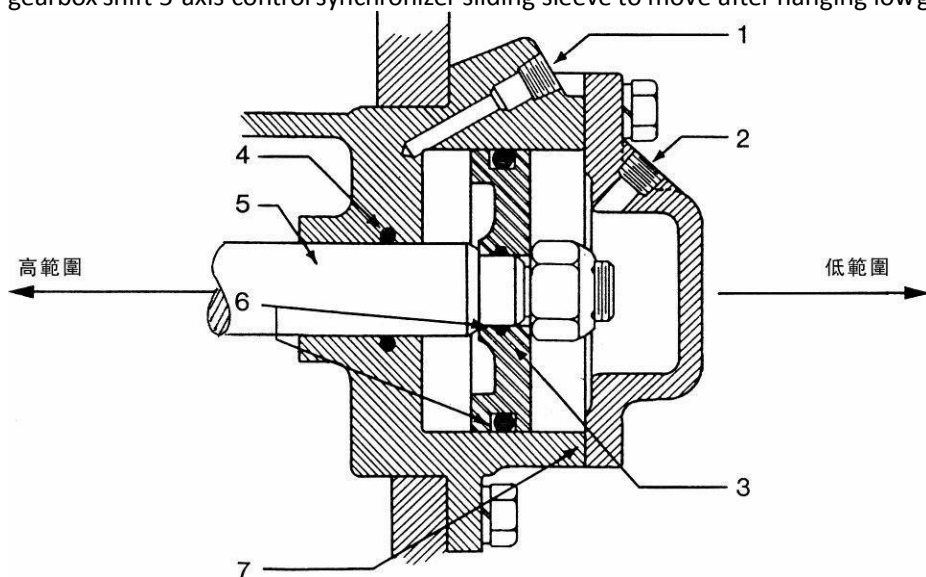

1 low speed working cylinder air control joint 2 high speed working cylinder joint 3 shift piston

4 "O" type sealing ring 5 shift shaft 6 "O" type sealing ring 7 shift cylinder

Figure 2-12 sub box high, low shift cylinder

When the gearbox cover the shift left axial (Figure 2-11) is pushed up to high gear position, dial rod boss double h shift valve core jacking, the pneumatic reversing valve, such as figure 2-12 at this time double h shift valve to high gear cylinder joint 2 to provide compressed air and low-speed gear cylinder joint 1 exhaust. This time the piston 3 together with the shifting shaft 5 is pushed forward, sliding sleeve hang into high gear (gear).

Push file hanging file as shown in Figure 2-10 and figure 2-12, gearbox hanging 1-2, the shift lever to promote the 1-2 shift shifting block, auxiliary transmission box hanging low gear. When the transmission gear 3-4 gear, the gear shifting rod block driven is 3-4 gear shifting block, pay the gearbox is still hanging low gear. When the gearbox 5-6, deputy gearbox in the double h shift valve and shift cylinder hung into high gear, but the main gearbox shift lever in the 5-6 gear shifting still is 1-2 gear shifting block. In other words: Gearbox by 4 gear change into 5 stalls, vice box by the low-speed gear shift into high gear and box is composed of 4 grade 1 file. Similarly, the gearbox to hang 6 files. Vice box linked to high speed, the main box hang 2 files and so on. Figure

2-10, 1-2,3-4 and 5-6,7-8 two "H" - shaped high and low, so called "double H" shift mechanism, in the arrangement of gear shifting blocks.

Figure 2-13 gives the vice box high, low-grade shift gas path control chart, because the whole car normal pressure is 7.5 ~ 8 bar, and high,Low-grade shift gas path does not need such a high pressure. Therefore, gas storage cylinder through a filtration pressure reducing valve will pressure decreased to 4.1 to 4.4 Bhatti supply double h shift valve as shown in Figure 2-13. General transport vehicles (truck, tractor, etc.) installed on the Fast gear box sub case no neutral position. Engineering vehicle (dump truck) with access for fast gear box, because of using the auxiliary box counter shaft power, so main box must hang together a forward gear position, take force device to work properly. Therefore under the car

suspended from the force condition, Fast gear box sub box must empty file.

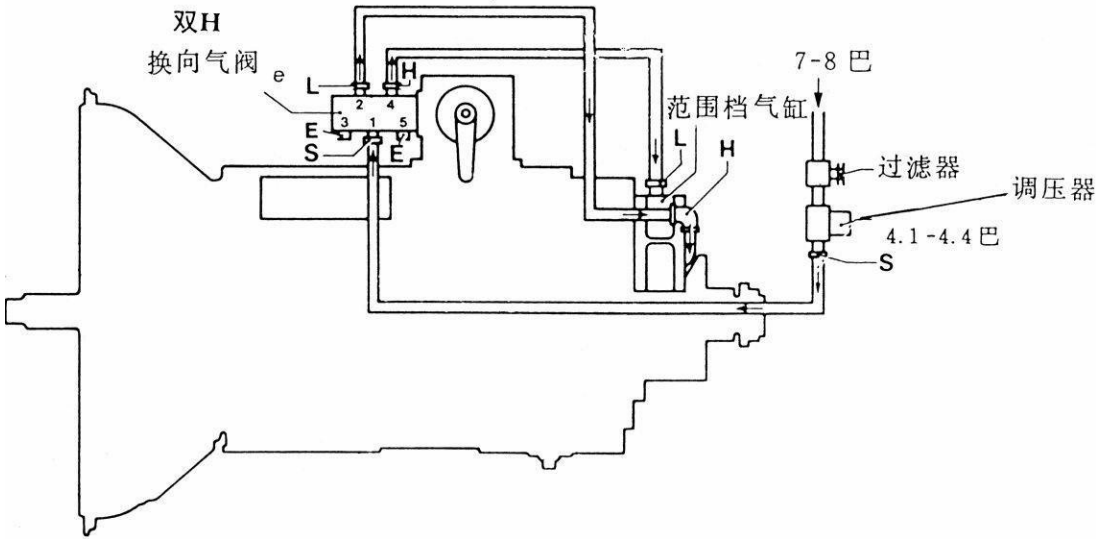

S. pressure relief valve from the compressed air E. dual H shift valve exhaust port L. connected to the working cylinder of the low speed gear working cylinder H. connection of the pipeline workingcylinder

2-13 auxiliary box is high, low shift gas diagram

Automotive Engineering Fast gear box high, low-grade shift cylinder structure such as figure 2-14. the gear shift cylinder must be matched with a working gap valve, neutral valve is a two position three-way valve, installed in the dashboard.

As shown in Figure 2-14 (I), when the shift lever is set low gear (1-2,3-4 file) position of, double h shift valve and the compressed air through to low gear air cylinder connector 1. At this point, if the neutral switch valve set "work" position, gap cylinder gas joint 6 by neutral valve leading to the atmosphere. At that time, low-grade shift piston 9 low-speed cylinder of compressed air towards the right end, shifting shaft driving device sliding sleeve hanging low gear. As shown in Figure 2-14 (II),When the gear lever set high gear (5-6,7-8) position, double h shift valve will be compressed air leads to high gear cylinder joint 3, and the low gear cylinder is communicated with the atmosphere. At this point, if the neutral switch is still home "work" position (i.e. gap cylinder joint 6 is communicated with the atmosphere), the piston 9 in high gear cylinder compressed air Next to the left end of the shaft through the gear shift synchronizer sleeve hanging high gear. As shown in Figure 2-14 (III),When the neutral valve is screwed to a "neutral" position, the compressed air through the gap valve open leading to gap cylinder joint 6, gap cylinder of compressed air the promotion of the activity of neutral Plug 4 to the middle position (stalls circle limit). At this point, if the gearbox hanging low gear (general force conditions gearbox hanging low-speed file 2), double h shift valve compression air input low speed cylinder, so as to promote the piston moves to the right, but moved to the middle position is neutral piston 4 limit. At this time, the auxiliary box synchronizer sliding sleeve in the neutral position.

General engineering vehicle power have two conditions: A in force taking device work need a car suspended immobile, such as dump truck in situ, turn off the bucket. This working procedure is: foot on the clutch, press the power electrical switching device, when the power take off clearance indicator lights said force taking device has been hanging in place. Then the gap switch valve screwed to a "neutral" position, the gear lever is pushed into the move two files, lift the clutch. At this time, the manipulation tipping bucket, drop handle, can be completed in situ, fall the tipping bucket task.

Another condition is required in the car moving force, such as car while walking, side dump. This working procedure is relatively simple: clutch foot under, press force taking device electric switch when indicating lamp bright said force taking device has been linked to the closed in place, will empty file switch valve remains in the original "work" position does not move, hanging forward gear, when the clutch pedal is lifted car to this file Moving forward at the same time, while the control of tipping bucket up, down the handle.

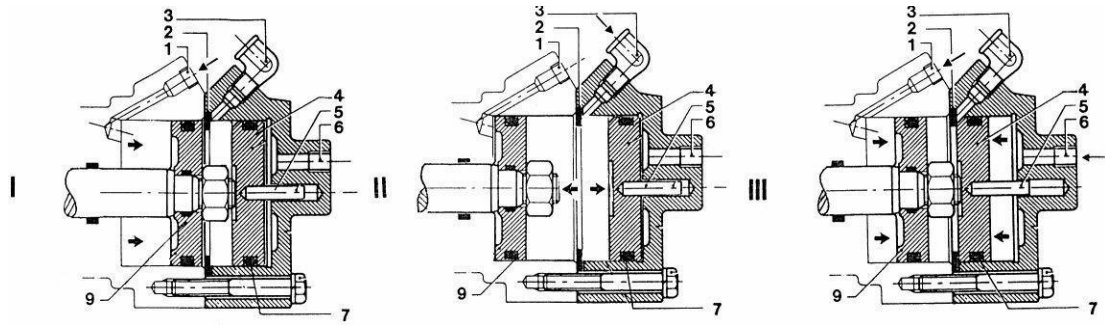

1. Low profile working cylinder of gas 2. Stalls circle 3. High speed cylinder gas joint 5. Neutral. Neutral piston piston connector guide rod 6. Neutral cylinder 7. Neutral piston joint sealing ring. Shifting piston

Figure  
2-14

With a neutral position high, low-grade shift cylinder Fast gear box main box counter shaft specifically set force taking gear, so it can from the main box from windows installation force taking device, then take force mode of operation and conventional gearbox there is not much difference. Generally heavy-duty engineering vehicles for the commonly used method of fetching force is to take power from the auxiliary box counter shaft and the method of fetching force in the work of the power device, main box must be hung low forward gears, which is differed from the conventional transmission operation.